

**Meadow Springs Improvement and Service District
2 Tandem Meter Pits with $\frac{3}{4}$ Meter, Pressure Reducing Valve and Electronic Read Transmitter
Invitation to Bid**

Meadow Springs Improvement & Service District will receive sealed bids until 5:00 p.m., February 10, 2016, for the purchase and installation of two (2) Tandem Meter Pits with $\frac{3}{4}$ Meter, Pressure Reducing Valve and Electronic Read Transmitter.

Bids must be provided in a sealed envelope with the statement “Meadow Springs Tandem Meter Pits Project” and received by the Meadow Springs Improvement and Service District, at PO Box 471, Gillette, WY, 82717 or delivered to Cathey Consulting, 400 South Gillette Avenue, Suite 106, Gillette, Wyoming, at or before the above stated time. Bids will be opened during the regularly scheduled District monthly meeting at 6:30 p.m. February 11, 2016. The District reserves the right to reject any or all bids. Wyoming preference laws must be followed by the designated contractor. Project must be completed and invoices submitted to the District no later than June 30, 2016.

Project specifications are posted online at www.catheyconsulting.net – select Meadow Springs and Meadow Springs again. For questions, contact John Benson at 307-682-7961.

PROJECT DESCRIPTION:

- 1) **Purchase and install two (2) Tandem Meter Pits with $\frac{3}{4}$ Meter, Pressure Reducing Valve, and Electronic Read Transmitter.**
- 2) **The District will mark where the two pits will need to be installed.**
- 3) **Each pit will contain lid, lid adapter, and a pillow.**
- 4) **Each pit installed will be brought to grade with minimum damage to the landscape.**
- 5) **A meter change out sheet needs to be filled out, which will be provided for each meter pit that is installed.**
- 6) **Brass fittings and stainless steel clamps need to be used on this project.**
- 7) **Each meter pit will need to be inspected by the District’s Certified Water Operator at the Contractor’s expense.**
- 8) **The specifications are as follows...**

Meadow Springs Improvement & Service District is located east of Gillette – Exit 132 (Wyodak exit), four miles north (on American Road).

ELECTION MAP

MEADOW SPRINGS IMPROVEMENT AND SERVICE DISTRICT



SCALE
1" = 500'



LEGEND

- ROAD CENTER MARKER
- 1/2" ROAD WITH CURB
- 60' ROAD AT 50' OFFSET
- POLE ROAD

LINE DATA

LINE	BEARING	DISTANCE
1	S 82°17' 30" E	285.37
2	S 80°17' 30" E	285.37
3	S 77°17' 30" E	285.37
4	S 74°17' 30" E	285.37
5	S 71°17' 30" E	285.37
6	S 68°17' 30" E	285.37
7	S 65°17' 30" E	285.37
8	S 62°17' 30" E	285.37
9	S 59°17' 30" E	285.37
10	S 56°17' 30" E	285.37
11	S 53°17' 30" E	285.37
12	S 50°17' 30" E	285.37
13	S 47°17' 30" E	285.37
14	S 44°17' 30" E	285.37
15	S 41°17' 30" E	285.37
16	S 38°17' 30" E	285.37
17	S 35°17' 30" E	285.37
18	S 32°17' 30" E	285.37
19	S 29°17' 30" E	285.37
20	S 26°17' 30" E	285.37
21	S 23°17' 30" E	285.37
22	S 20°17' 30" E	285.37
23	S 17°17' 30" E	285.37
24	S 14°17' 30" E	285.37
25	S 11°17' 30" E	285.37
26	S 8°17' 30" E	285.37
27	S 5°17' 30" E	285.37
28	S 2°17' 30" E	285.37
29	S 0°17' 30" E	285.37
30	S 323°17' 30" E	285.37

CURVE DATA

STATION	PC	PT	PI	STATION	PC	PT	PI
1+00	363.00	363.00	363.00	1+00	363.00	363.00	363.00
1+11	374.11	374.11	374.11	1+11	374.11	374.11	374.11
1+22	385.22	385.22	385.22	1+22	385.22	385.22	385.22

LAND DESCRIPTION

- SECTION 11, T8N, R10E
- SECTION 12, T8N, R10E
- SECTION 13, T8N, R10E
- SECTION 14, T8N, R10E
- SECTION 18, T8N, R10E
- SECTION 24, T8N, R10E
- SECTION 25, T8N, R10E
- SECTION 26, T8N, R10E
- SECTION 27, T8N, R10E
- SECTION 28, T8N, R10E
- SECTION 29, T8N, R10E
- SECTION 30, T8N, R10E

DATE
12/05/75
1/11/79
ELECTION MAP

MEADOW SPRINGS IMPROVEMENT & SERVICE DISTRICT	
APPROVED BY	DATE

MUELLER® THERMAL-COIL® METER BOX

Mueller Co.

8F.1

Shaded area indicates change Rev. 4-14



The MUELLER THERMAL-COIL Meter Box provides a means to allow a meter to be read and maintained even though it is set deep in the ground to resist freezing. The THERMAL-COIL Meter Box is designed with the meter installed on a platform that normally sets near the bottom of the box where the ground temperature keeps it warmer. The meter and platform are connected to the service line by coils of polybutylene tubing which allow the meter and platform to be raised to the surface.

The body of the meter box is made from rigid PVC which has a high insulating "R" value to resist frost bridging* inside the box. For extremely cold climates, an optional insulating pad is available which traps the relatively warm air rising from the earth inside the box.

MUELLER THERMAL-COIL Meter Boxes are shipped fully assembled, ready for meter installation. Their light weight saves shipping costs and makes installation a one man job in most cases. Every box is factory tested and has a 150 psig maximum working pressure rating.

MUELLER THERMAL-COIL Meter Boxes are available for 5/8" to 1" meters. A wide variety of end connections, control valves, box depths, lids and other options provide you with the meter set you need. Due to the almost endless combination of features available, each box is custom built to your specifications. See page 8F.2 for options and ordering instructions.

Manufactured under one or more of the following: U.S. Patent No. 4,614,113; 4,813,281

MUELLER THERMAL-COIL Meter Box Features

- Rigid .300 minimum wall PVC material holds shape and resists frost bridging
- Optional insulation pad traps earth's heat to prevent freezing in extremely cold climates
- White interior aids visibility
- Meter set is anchored to moveable platform to maintain alignment and stability
- Platform support and reinforcing ring add rigidity to box
- Poly coil tubing provides low friction loss equivalent to a typical conventional meter set of the same size and depth
- Male I.P. thread inlet and outlet connections accept a variety of MUELLER Service Fittings--see section 6
- Optional aluminum bottom available
- Large selection of optional lids

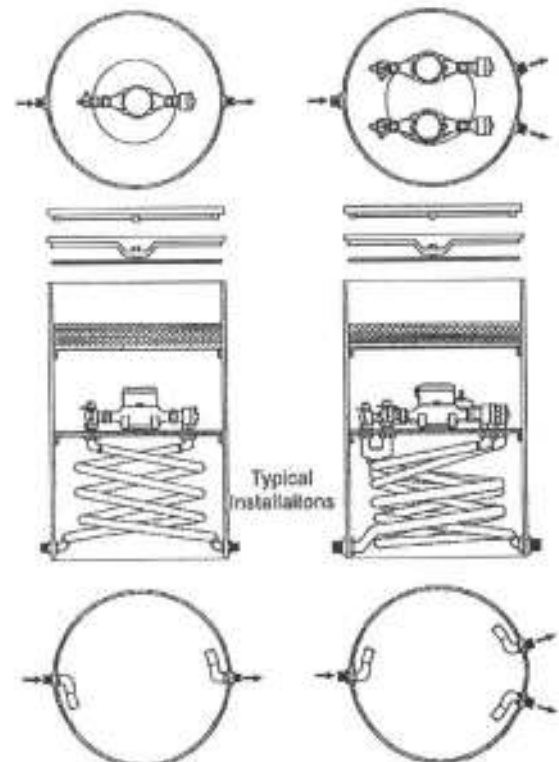

MUELLER Valves and Couplings used in these meter box assemblies are manufactured and tested in accordance with ANSI/AWWA C900. Components in contact with potable water will also comply with test requirements of the Federal Safe Drinking Water Act.

8F.2



MUELLER® THERMAL-COIL® METER BOX

Rev. 8-14 Shaded area indicates change

MUELLER THERMAL-COIL Meter Box ordering instructions

To order a MUELLER THERMAL-COIL Meter Box, simply choose the options you require from the nine categories listed below and place the option code on the appropriate

line of the catalog number shown below. If the box you need is a tandem type, please fill out the tandem information box shown below the options listing and contact the factory for price and delivery information. Phone 1-800-423-1323 or fax 1-217-426-7537.

Catalog Number

(1) _____ (2) _____ (3) _____ (4) _____ (5) _____ (6) _____ (7) _____ (8) _____ (9) _____

Options

- 1 Meter size**
NOTE: Meter is not furnished. Order meter separately.

Meter Size	Code Number
5/8"	200
5/8" x 3/4"	203
3/4"	250
1"	330

- 2 Box Style**

Box Style	Code Number
Single meter	CS
Double meter	CD
Tandem	CT

- 3 Box diameter**

Box Diameter	Code Number
16" box is for use with: 5/8, 5/8 x 3/4 or 3/4 single meters; 5/8, 5/8 x 3/4 or 3/4 tandems*	15
18" box is for use with: 1" single meters; 1" tandems; 5/8, 5/8 x 3/4 or 3/4 double meters	18

- 4 Box depth**

Depth	Code Number	Depth	Code Number
30"	30	66"	66
36"	36	72"	72
42"	42	78"	78
48"	48	84"	84
54"	54	90"	90
60"	60	96"	96

- 5 Meter inlet type**

Meter Inlet	Code Number
Meter coupling	A
Lockwing angle meter stop	L
Lockwing angle ball valve (full port)	F
Lockwing angle ball valve (reduced port)	R

- 6 Meter outlet type**

Meter Outlet	Code Number
Meter coupling	A
Dual check valve	B
A.S.S.E. Dual check valve	S
A.S.S.E. Top entry vertical check	V
Lockwing angle meter stop	L
Lockwing angle ball valve (full port)	F
Lockwing angle ball valve (reduced port)	R

- 7 Box bottom type**

Bottom Type	Code Number
Attached aluminum bottom	A
Less bottom	B

- 8 Type of box locking device** (box is ordered with device to accept either a non-locking lid, center locking or side locking lid). Lids must be ordered separately.

Lock Type	Code Number
Non-locking	N
Center locking	L
Side locking	S

- 9 No lead brass**

Code Number
N

Tandem box order information

Type of tandem device (regulator, backflow preventer, etc.) _____
 Size _____, lay length _____ and end connections (M.I.P., F.I.P., etc.) _____ of the tandem device
 Tandem device manufacturer's name _____ Tandem device model number _____

* NOTE: Tandem device is not included and must be purchased separately. ALSO, 3/4" tandem systems when used with certain regulators may need to be placed within a 18" box; list the regulator model when specifying this system. If an ASSE check valve or ball valve is being used in a 3/4" setting then an 18" meter box will be required.

MUELLER Valves and Couplings used in these meter box assemblies are manufactured and tested in accordance with ANSI/AWWA C800. Components in contact with potable water will also comply with latest requirements of the Federal Safe Drinking Water Act.

For Residential and Commercial Applications

Job Name _____
 Job Location _____
 Engineer _____
 Approval _____

Contractor _____
 Approval _____
 Contractor's P.O. No. _____
 Representative _____

LEAD FREE*

Series LFN45B-M1 Water Pressure Reducing Valves**

Sizes: 1/2" - 1" (15 - 25mm)

Series LFN45B-M1 Water Pressure Reducing Valves are designed to reduce incoming water pressure to a sensible level to protect plumbing system components and reduce water consumption. The LFN45B features Lead Free* construction to comply with Lead Free* installation requirements. This series is suitable for water supply pressures up to 400psi (27.6 bar) and may be adjusted from 25 - 75psi (172 - 517 kPa). The standard setting is 50psi (345 kPa). All parts are quickly and easily serviceable without removing the valve from the line. The standard bypass feature permits the flow of water back through the valve into the main when pressures, due to thermal expansion on the outlet side of the valve, exceed the pressure in the main supply.

Features

- Double union inlet & outlet connections (option DU)
- Integral stainless steel strainer
- Thermoplastic seat & cage
- Lead Free* cast copper silicon alloy body construction
- Serviceable in line
- Bypass feature controls thermal expansion pressure***
- Sealed spring cage on all models for accessible outdoor or pit installations

Models

LFN45B-M1	NPT threaded female inlet x NPT female outlet
LFN45BU-M1	NPT threaded union inlet x NPT female outlet
LFN45BU-S-M1	Solder union inlet x NPT female outlet
LFN45BU-QC-M1	Single Union - QC union inlet
LFN45BDU-M1	Double Union - NPT threaded union female inlet and outlet
LFN45BDU-S-M1	Double Union - Solder union inlet and outlet
LFN45BDU-PEX-M1	Double Union - PEX union inlet and outlet (3/4" and 1" only)
LFN45BDU-CPVC-M1	Double Union - CPVC union inlet and outlet (3/4" and 1" only)
LFN45BDU-QC-M1	Double Union - QC union inlet and outlet (3/4" and 1" only)

Specifications

Standard Specifications: A Water Pressure Reducing Valve with integral strainer shall be installed in the water service pipe near its entrance to the building where supply main pressure exceeds 60psi (413 kPa) to reduce it to 50psi (345 kPa) or lower. The water pressure reducing valve shall be constructed using Lead Free* materials. Lead Free* regulators shall comply with state codes and standards, where applicable, requiring reduced lead content. The valve shall feature a Lead Free* cast copper silicon alloy body suitable for water supply pressures up to 400psi (27.6 bar). Provision shall be made to permit the bypass flow of water back through the valve into the main when pressures, due to thermal expansion on the outlet side of the valve, exceed the pressure in the main supply. Water Pressure Reducing Valve with built-in bypass check valves and integral strainer will be acceptable. Approved valve shall be listed to ASSE 1003 and IAPMO and certified to CSA B356. Valve shall be a Watts Series LFN45B-M1.

Watts product specifications in U.S. customary units and metric are approximate and are provided for reference only. For precise measurements, please contact Watts Technical Service. Watts reserves the right to change or modify product design, construction, specifications, or materials without prior notice and without incurring any obligation to make such changes and modifications on Watts products previously or subsequently sold.

LFN45BDU-M1

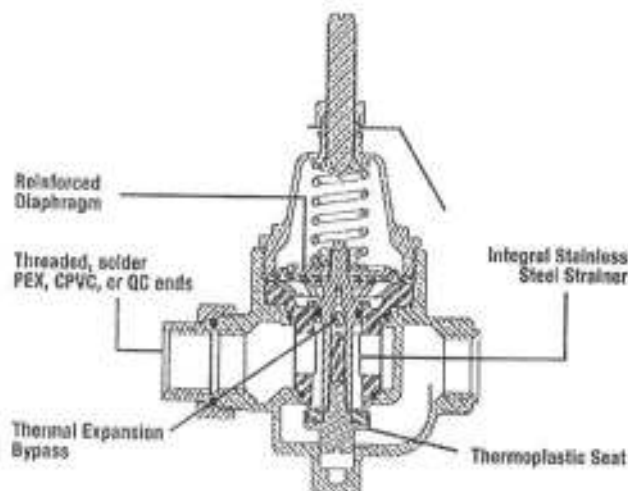

*The wetted surface of this product contacted by consumable water contains less than 0.25% of lead by weight.

**A water saving test program concluded that reducing the supply pressure from 60-50psi (551-345 kPa) resulted in a water savings of 30%.

***The bypass feature will not prevent the pressure relief valve from opening on the hot water supply system with pressure above 160psi (10.3 bar).

WATTS®

Materials

Body:	Lead Free* cast copper silicon alloy
Seat:	Thermoplastic
Cage:	Thermoplastic
Integral Strainer:	Stainless steel
Diaphragm:	Reinforced EPDM
Valve Disc:	Elastomer

Pressure – Temperature

Temperature Range: 33°F – 180°F (0.5°C – 82°C)
 Maximum Working Pressure: 400psi (27.6 bar)
 Adjustable Reduced Pressure Range: 25 – 75psi (172 – 517 kpa)
 Standard Reduced Pressure Setting: 50psi (345 kpa)

Standards



Meets requirements of ASSE Standard 1003, (ANSI A112.26.2) and CSA Standard B356. Certified by NSF to ANS/NSF Standard 61 Annex G. Listed by WPMO and City of Los Angeles.

Options

Add Suffix

- G Gauge tapping
- GG Gauge tapping and 160psi (11.0 bar) gauge

Dimensions – Weights

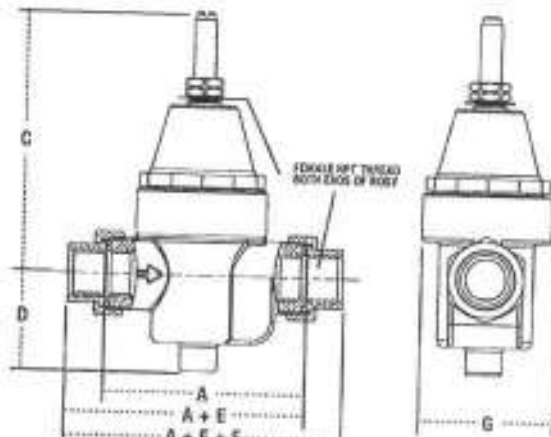

ALWAYS SHOW WITH SINGLE LEFT HAND CONNECTION ON LEFT
 SHOWS ANY OF 4 CONNECTIONS WITH 0.125" UNION CONNECTIONS USING ANY
 EQUIVALENT OF NPT, BEEDEE, FOR OR OTHER CONNECTION PROGRAM
 *F DIMENSIONS ARE APPROXIMATE DIMENSIONS LISTING

Capacity

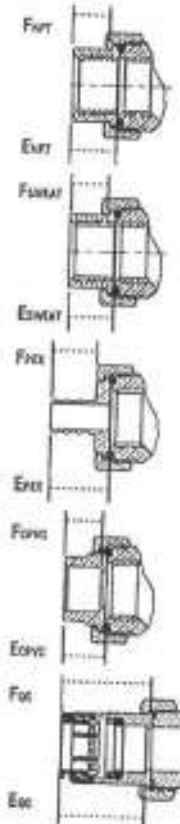
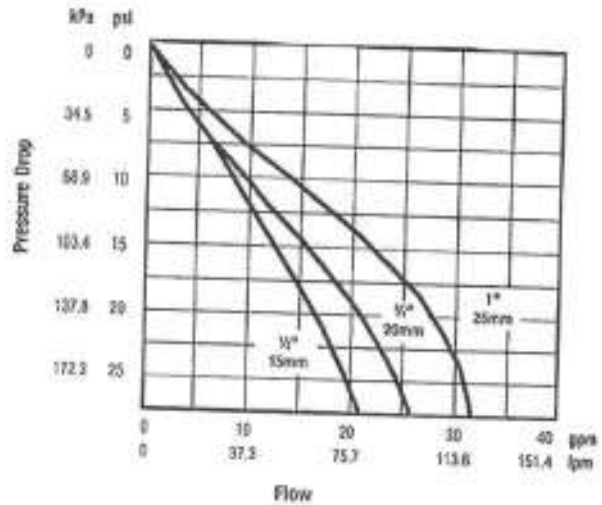







SIZE (mm)		DIMENSIONS														WEIGHT																																																																																												
In.	mm	A	C	D	E1	E2	E3	E4	E5	E6	E7	E8	E9	E10	E11	E12	E13	E14	E15	E16	E17	E18	E19	E20	E21	E22	E23	E24	E25	E26	E27	E28	E29	E30	E31	E32	E33	E34	E35	E36	E37	E38	E39	E40	E41	E42	E43	E44	E45	E46	E47	E48	E49	E50	E51	E52	E53	E54	E55	E56	E57	E58	E59	E60	E61	E62	E63	E64	E65	E66	E67	E68	E69	E70	E71	E72	E73	E74	E75	E76	E77	E78	E79	E80	E81	E82	E83	E84	E85	E86	E87	E88	E89	E90	E91	E92	E93	E94	E95	E96	E97	E98	E99	E100	In.	lbs	mm	kg
1/2	15	3 3/8	88	4 3/8	116	1 1/2	43	3/8	10	5/8	15	1 1/8	21	3/4	15	1 1/8	36	1/2	13	3/8	16	1/2	13	1 1/8	38	2 1/4	57	2	91																																																																															
3/4	20	3 3/8	88	4 3/8	116	1 1/2	43	5/8	16	3/4	21	1 1/8	24	1 1/8	21	1 1/8	40	5/8	14	3/4	18	3/4	18	1 1/8	42	2 1/4	57	2	91																																																																															
1	25	4 1/4	105	4 3/8	116	1 1/2	43	3/4	20	1	26	1 1/8	29	1 1/8	26	1 1/8	43	3/4	17	1 1/8	23	1 1/8	23	1 3/4	45	2 1/4	57	3	1.36																																																																															

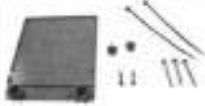
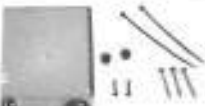

USA: Tel: (978) 688-1811 • Fax: (978) 794-1848 • www.watts.com
 Canada: Tel: (905) 332-4090 • Fax: (905) 332-7068 • www.watts.ca

100W Datalogging Water ERT Module Accessories

Ordering Instructions		Order in multiples of 12 (single box quantity).		
	Part Number	Qty	Description	Notes
	CFG-0900-003	1	Remote mount antenna kit	For use in lids without a pre-drilled hole.
Ordering Instructions		Order in multiples of 24 (single box quantity).		
	Part Number	Qty	Description	Notes
	CFG-1300-001	1	Shelf mount kit	For use with pit lids that have a shelf-mounting pocket.
	Part Number	Qty	Description	Notes
	CFG-1300-004	1	Through lid mount kit	For use in lids with a pre-drilled hole. Suitable for lids up to 1 3/4" thick and hole diameters from 1 3/4" to 2 inches.
Ordering Instructions		Order in multiples of 30 (single box quantity).		
	Part Number	Qty	Description	Notes
	CFG-0771-021	1	Mounting kit for remote installations.	Kit includes adapter plate, remote mount screws, mounting screws, cable ties and tamper seals.
	Part Number	Qty	Description	Notes
	CFG-1300-003	1	Mounting kit for remote installation with a telemetry device	Kit includes adapter plate, remote mount screws, mounting screws, cable ties and tamper seals.
	Part Number	Qty	Description	Kit includes pipe clamp, bracket screws, remote mount screws, mounting bracket, and adapter plate.
	CFG-0217-501	1	Pipe mount kit for pipe diameters up to 4"	
	CFG-0217-503	1	Pipe mount kit For pipe diameters between 3/4" to 1-3/4"	
	CFG-0217-504	1	Pipe mount kit For pipe diameters between 1-5/16" to 2 1/4"	
	TDC-0909-XXX		100W and 100WP Pit Datalogging Water ERT Module Installation Guide	Included with initial order. XXX designates revision level and is subject to change without notice.
	TDC-0951-XXX		100W-R and 100WP-R Datalogging Water ERT Module Installation Guide	Included with initial order
	PUB101161 EM-01	1	100W Series Communication Module Installation Guide Best-practices Instructional DVD	An instructional DVD guide to 100W ERT module installation.



■ BELLWETHER TECHNOLOGY FOR LEAKS AND LOW FLOW



This bellwether technology is a worldwide standard in precise flow measurement suitable for all water conditions. In North America, Master Meter is the undisputed leader in multi-jet products.

Technical Specifications:

- **AWWA Standard** - Meets or exceeds all sections of AWWA Standard C-708, most recent revision. Optional NSF/ANSI Standard 61 certified no lead main case available.
- **Design/Operation** - Velocity-type flow measurement. Water that is evenly distributed by multiple converging inlet ports flows past an impeller in the measuring chamber, creating an impeller velocity directly proportional to water flow rate. The meter's register integrates that velocity into totalized flow. The register assembly is removable under line pressure permitting seamless, simplified upgrades in reading technology.
- **Measuring Chamber** - The measuring chamber housing and measurement element are built with an advanced synthetic polymer. Measurement surfaces are not wear surfaces, providing sustained accuracy despite the presence of entrained solids in the water. A long life, synthetic sapphire bearing serves as a wear surface with radially balanced water flows. The chamber housing is constructed in two parts to allow access to the impeller. Bottom plates available in Bronze, Cast Iron (CI) or Engineered Plastic.

Features & Benefits:

- Clean, elegant measurement design is highly sensitive to leaks and low flow while limiting wear for excellent revenue protection.
- Measures with only moving part moving part that is hydro-dynamically balanced on a sapphire bearing to preserve accuracy for the life of the meter.
- Exceptional capabilities for passing entrained solids and operating in environments with high mineral content.
- Proprietary design produces smooth, laminar flow profile for improved, sustained accuracy.
- Rugged basket strainer built from advanced polymer materials for superior wear mitigation.
- Creates an exceptional measurement foundation on which to add Dialog 3G Mobile, FixedLinx, and GridLinx AMI data solutions.
- Accuracy meets or exceeds the AWWA C-708 Standard. Optional NSF Certification Available.

Master Meter is a registered trademark of Master Meter, Inc. All other trademarks are the property of their respective owners.



Technical Specs (Cont'd):

- **Register Sealing** - Direct read and DIALOG® registers are permanently sealed with a scratch resistant glass lens, stainless steel base and wrap-around gasket to prevent intrusion of dirt or moisture. Available in USG, CF or M³. Equipped with center mounted low flow leak indicator with high sensitivity resulting from direct one to one linkage to measuring element and large center sweep hand with one hundred (100) clearly marked gradations on the periphery of the dial face.
- **Strainer** - A rugged, 360-degree advance polymer basket strainer protects the critical measuring element from damage. The unique strainer design smoothes the flow of water entering into the meter

creating a laminar flow that is gentle on the meter's internal components. Tough materials operating in a smooth, balanced environment enable the meters to perform more accurately over time. Utilities' investments last longer while capturing more revenue.

- **Magnetic Drive** - A reliable, direct magnetic drive provides linkage between measurement element and register. No intermediate gearing is required; no gearing is exposed to water.
- **Tamper Detection** - The Master Meter Multi-jet adjusting port and register are concealed to prevent tampering and removal of the register. This design also provides a visual indication of tampering attempts.

METER OPERATING CHARACTERISTIC/DIMENSION	5/8"	3/4" x 7-1/2"	3/4" x 9"	3/4" x 9" x 1"	1"
Flow Rating (gpm)	20	30	30	30	50
Continuous Flow (gpm)	15	20	20	20	30
Normal Flow Range (gpm)	1-20	2-30	2-30	2-30	3-50
Maximum Working Pressure (psi)	150	150	150	150	150
Maximum Working Temperature (F)	120	120	120	120	120
Length (A below)	7-1/2"	7-1/2"	9"	9"	10-3/4"
Width (B below)	3-5/8"	3-5/8"	3-5/8"	3-5/8"	4"
Height, standard register with lid (C below)	5"	5"	5"	5"	5-1/4"
Height, bottom to center line (D below)	1-1/2"	1-1/2"	1-1/2"	1-1/2"	1-3/4"
Weight (lbs)	3.95	4	4.1	4.6	5.25
Packed To Carton	6	6	6	4	4
Carton Weight (lbs)	25.1	25.4	26	19.8	22.4

Accuracy and Head Loss Chart

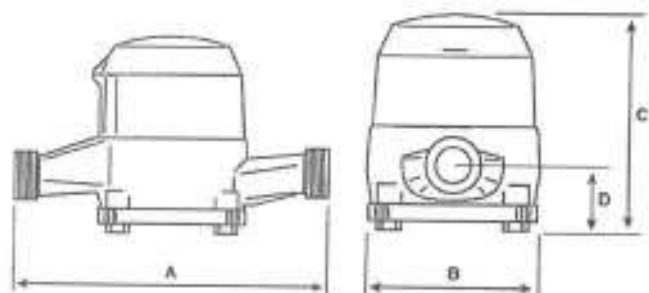
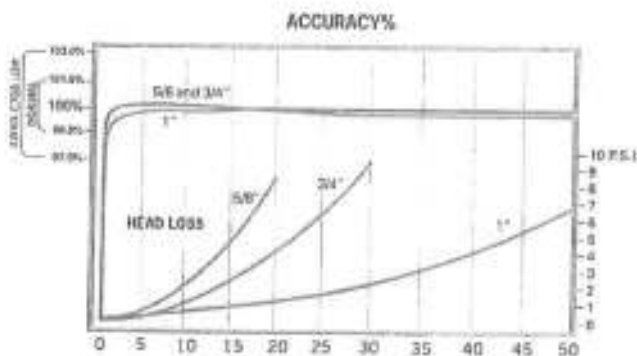



100W

Water Communication Module

The 100W ERT® communication module is the latest addition to Itron's portfolio of advanced metering devices for water utilities. Featuring a compact design, industry-leading battery life and technology designed to adapt and grow with your business, the 100W module can help you streamline your operations and maximize your resources today and into the future.

100W ERT modules are available in two housing designs, supporting both water pit and remote installations. The different 100W ERT modules are identified as follows:

- 100W is to be utilized with encoder registers in a pit environment
- 100WP for pulser registers in a pit environment
- All new 100W ERT modules for pit applications will come standard with a red integral connector port to utilize the optional 100W Through-The-Lid (TTL) antenna
- 100W-R for encoder registers in remote applications
- 100WP-R for with pulser registers in remote applications

These modules offer advanced two-way meter data collection designed specifically for Itron collection systems using handheld, mobile, fixed network and combination hybrid solutions. 100W ERT modules differentiate themselves from other devices on the market by providing true two-way

communications capabilities. Engineered from the ground up to leverage the benefits of ChoiceConnect™ collection systems, 100W ERT modules enable easy migration from mobile to fixed network operations as your business needs evolve. With Itron's complementary communications technology, fixed and mobile network systems can be deployed side-by-side in hybrid configurations to ensure maximum efficiency and reliability in both high and low-density meter populations.

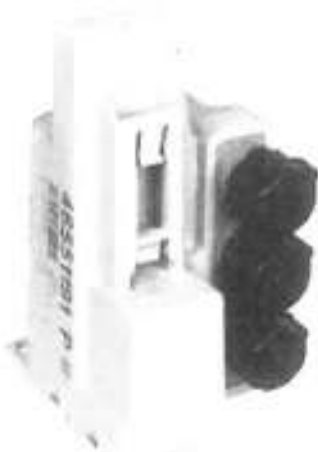

100W

Water Meter Compatibility

The 100W ERT module is compatible with industry-leading water meters from Itron—as well as those from all major manufacturers such as Badger, Elster AMCO, Hershey, Master Meter, Neptune and Sensus—enabling water utilities to consolidate all their water meters under a single reading system. Powered by proven, advanced lithium battery technology, the module is designed for 20 years of battery life in both fixed network and mobile modes.

Data Logging

The 100W ERT module stores 40 days of hourly consumption information, which can be collected by the fixed network system to leverage real time data collection or can be read by mobile or handheld systems. This data is presented in four basic use cases:

- Any hourly reading within the last 40 days
- A set of 24 consecutive hourly readings
- A set of 40 daily readings
- A set of 40 days of hourly interval data are available even in mobile mode

Superior Performance

The 100W ERT module utilizes 120 radio channels in Fixed Network and 50 radio channels in mobile and handheld modes, randomly selecting one channel for each data message. This multi-channel approach delivers higher read integrity over competing products by reducing the effect of interfering signals from other radio frequency (RF) signals in the area. The 100W ERT module will transmit the Fixed Network consumption messages at peak radiated power greater than 1 Watt.

Reliability

100W ERT modules feature a circuit assembly and battery pack that are fully encapsulated within a specially-formulated potting material to completely protect internal components from water, contaminants, corrosion, rough handling and temperature cycling. With their straight forward, rugged design, 100W ERT modules use substantially fewer components than most competing products, resulting in greater reliability. The advanced, integrated antenna operates effectively in a wide range of meter box installations. The 100W ERT module offers peace of mind with a 20 year limited warranty.

Lower Cost of Ownership

100W ERT module devices feature industry-leading battery life, ensuring your meter data collection investment achieves substantially better financial returns than competing products with batteries that typically last only ten or twelve years. When one considers the advancements in leak, reverse flow (absolute encoder version only) and tamper detection, 100W modules necessitate fewer field investigations and substantially lower expenditures for installation, meter reading, customer service and field service. And with a low battery alarm, these modules help utilities better plan and manage the replacement of units in the field.

Leak Management

Water loss management is critical to any water utility's success. 100 Series modules can be paired with Itron's advanced acoustic Leak Sensor. The Leak Sensor collects and analyzes changes in pipe acoustics that indicate probable leaks in the distribution system environment to detect both new and pre-existing leaks automatically. Leak Sensor technology, coupled with the module's internal customer-side leak detection algorithm and the option to use data from groups of 100W ERT modules (District Metering) provide the utility with a highly accurate picture of the overall health of the water distribution system.

Leak Data

The 100 Series collects and stores the data from the Leak Sensor. The Leak Sensor samples the pipe conditions every 22.5 minutes or 64 times daily. The 100 Series stores the 8 quietest analyses daily and will hold 20 days worth of data. This data is picked up during normal meter reading operations and seamlessly transfers the data to our hosted web based solution (mlogonline).



100WR

100W ERT MODULE SPECIFICATIONS

Functional

- Power Source: Two "A" cell lithium batteries warranted for 20 years
- Maximum meter register pulse frequency (pulse version only): 4 Hertz
- Operating temperature:
 - -40°C to +70°C for remote applications
 - -20°C to +60°C for pit applications
- Storage temperature: -40°C to +75°C for maximum of 1,000 hours
- Humidity limits: 0 to 100% (submersible)
- Maximum register cable dimension: 300 feet with Itron-approved cable and splice connectors
- Meter compatibility: See Water Module Meter Compatibility Guide (PUB-0063-002)

Transmission Parameters

- Data message:
Multiple RF channel transmissions of meter register value, cut cable and or communication error (tamper), reverse flow (encoder version only) and system leak status messages, as well as low battery indicator is transmitted every nine seconds in mobile mode. All this information and last 7 line synchronized consumption intervals is transmitted every five minutes along with a contingency SCM (Standard Consumption Message) every 60 seconds in fixed network mode
- Transmitter frequencies:
 - 908 – 924 MHz (Standard Power) in mobile mode
 - 903 – 928.8 MHz (High Power) in fixed network mode
- Operates in bubble-up mode and does not require a license from the Federal Communications Commission (FCC) or Industry Canada (IC)
- FCC Part 15.247
- Industry Canada, RSS-210

Approved Reading Devices for Collecting Datalogging Reads

- Network system: Itron Fixed Network 100 Collectors and Repeaters (CCU 100 and Repeater 100) which offer full two-way communication capability.
- Drive-by system:
 - MC3 with MV-RS v8.0 or higher and FCS with v2.2 or higher
 - MC Lite with MV-RS v8.1 or higher and FCS with v2.3 or higher
- Walk-by system:
 - FC300 with SRead handheld computers with MV-RS v8.1 or higher and FCS with v2.3 or higher
 - FC200SR (part number FC2-0005-004 or FC2-0006-004 will support datalogging) handheld computer with MV-RS v8.1 or higher and FCS with v2.3 or higher

Approved Reading Applications

- Multi Vendor Reading System (MV-RS) v8.1 or higher or FCS v2.2 or higher software can read the 100W ERT module Standard Consumption Message (SCM) and Datalogging with the following reading devices: MC3 v3.3 or higher
- Multi Vendor Reading System (MV-RS) v8.2 or higher can read the 100W ERT module Standard Consumption Message (SCM) and Datalogging with the following reading devices: MC3 v3.3 or higher, FC300SR, FC200SR, and MCLite

Approved Programming Devices

- FC200SR with Field Deployment Manager (FDM) version 1.1 or higher software
- FC300SR with Field Deployment Manager (FDM) version 1.1 or higher software
- 900 MHz Belt Clip Radio Field Deployment Manager (FDM) version 1.1 or higher software

The 100W encoder version does not require any programming—it automatically detects the register type within one hour of being connected. 100W ERT modules do not require a FCC license.

Programmable Mode Options:

- Mobile/Handheld Mode
 - This is the standard mode in which all 100W ERT modules will be shipped. This mode should be utilized when mobile or handheld meter reading will be the primary method of collecting the Standard Consumption Message (SCM) or datalogging reads.
 - The SCM will bubble-up in this mode every 9 sec. at standard power optimized for mobile read rate performance.
 - The battery life for this mode is 20 years
- Fixed Network (FN) Mode
 - This mode is to be utilized when fixed network will be the method of meter data collection
 - A high power Network Interval Message (NIM) will be transmitted every 5 minutes with a contingency SCM message transmitted every minute at standard power
 - FN mode can be programmed at the factory, during installation with an approved handheld device or through mobile application after initial installation and programming
 - The battery life for this mode is 20 years
- Hard-to-Read Mobile/Handheld Mode
 - This mode should only be used when communication modules are installed in difficult to read locations where standard mobile mode is not sufficient for satisfactory reading performance
 - This mode will bubble-up an SCM at 30 seconds with high power output to optimize performance of these unique applications
 - The battery life of this mode is greater than 10 years

